

## 5 APPROVAL

**PASSADOME®** access hatches are guaranteed for ten years as closed, covered units (when installed and used in accordance with our specification). **PASSADOME®** units conform to regulatory standard NFP 37-418. Waterproofing details conform to British Standard BS 8217:2005.

**PASSADOME®**, with its structured polycarbonate glazing, is approved by the CSTB Avis Technique No. 2/03-1027.

Resistance to upward static load: 1000 pa (1000 N/m<sup>2</sup>)

Resistance to downward static load: 1500pa (1500 N/m<sup>2</sup>)

Fire rating data and 1200 joules test data can be found on the website: [www.skydome-axt.com](http://www.skydome-axt.com) under the heading "Espace Partenaires" (Partner information).

## 6 OPTIONS

- Steel kerb pre-painted in CLASSIC WHITE
- Steel kerb painted after manufacture to any of the main RAL colours.
- Opening grill tested to 1200 joules.
- Painted opening grill tested to 1200 joules.
- Ladder attachment bar (BAE)
- Grab handle in galvanised steel
- Painted finish
- Domes 1200 joules, pyramid domes
- Quadruple-walled PCA 10, PCA 16, etc.
- Alternative technical solution to adapt unit to roof with PVC waterproofing.

### Options for Adapter Plates:

- Insulation
- Length of foot from 50 to 180mm (or more on request).

## 8 GEOMETRIC DIMENSIONS

DIMENSIONS OF ROOF OPENING A x B* (cm)	LIGHT TRANSMISSION SURFACE (m <sup>2</sup> )	OVERALL DIMENSION C x D* (cm)	PASSADOME®			
			H (cm)		H1 (cm)	
			With domes	With structured polycarbonate	With domes	With structured polycarbonate
85 x 85	0.72	103 x 103	56	39	42	25
100 x 100	1.00	118 x 118	58	39	44	25
120 x 120	1.44	138 x 138	60	39	46	25

\*B & D are the hinged and longest sides of the unit.

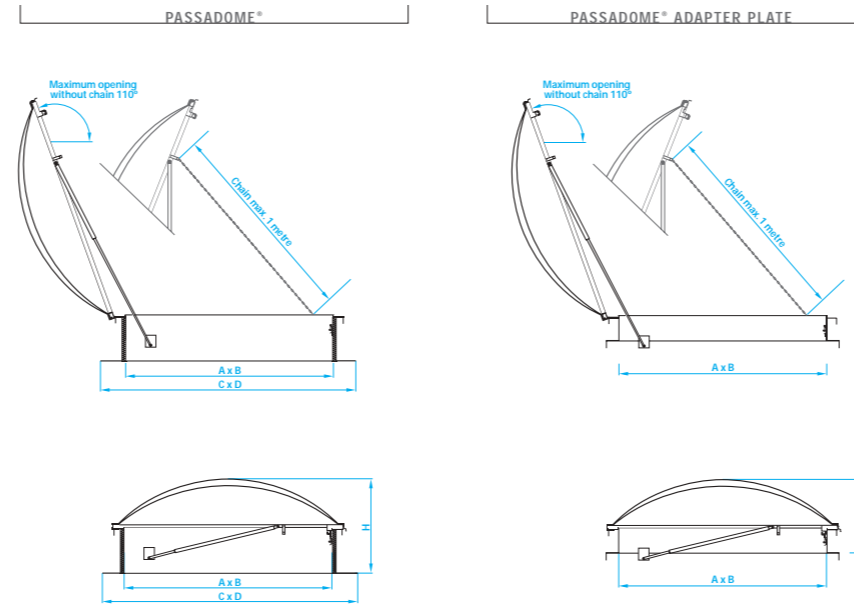

## ACCESS HATCH/ROOFLIGHT

# PASSADOME®

Ref. Passadome® 09/2005. The manufacturer reserves the right without notice to modify the composition of its products. Characteristics provided in this particular dossier from data obtained under controlled test conditions. Axtex makes no warranties, express or implied, as to the properties and performance under any conditions from such conditions in actual construction. OUR FOUR COMMUNICATIONS.

## 7 INSTALLATION

Installation should be carried out in accordance with current regulations. Decks should be sound and resistant and should conform to the requirements of current decking standards and of the installation guide.

Maximum roof slope: 25°, i.e. 45%.

If the slope of the roof is less than 25°, the hinged side of the unit must be parallel to the slope. If the slope of the roof is less than 3° there is no particular requirement.

**Fixing:** in accordance with the current DTU standards series 43, in the case of a standard kerb, on metal, timber or concrete deck. If an adapter plate (or covering kerb) is used, this is adapted for installation on to the existing kerb or concrete surround (see installation guide).

### Waterproofing seal:

- The bitumen-faced insulation on the standard kerb guarantees a seal with waterproofing detailing material.
- Zinc or lead flashing should be installed in situ to create a seal with roof tiles or slates.
- A co-laminated metal sheet is used for PVC membranes.

**Maintenance:** Glazing must be washed with soapy water. Corrosive products or solvents must not be used.

**AXTER**

AXTER LTD  
Cliff Road Ipswich Suffolk IP3 0AY - UK  
Tel : 01473 217154 - Fax : 01473 232118  
<http://www.axter.co.uk> - Email : [sales@axterltd.co.uk](mailto:sales@axterltd.co.uk)

**AXTER**



PASSADOME® is a rooflight unit designed to provide roof access and to allow natural daylight into a building. It is used on flat and low slope roofs with waterproofing and on tiled or slate pitched roofs on all types of buildings:

- Public access buildings
- Industrial buildings
- Commercial buildings, offices
- Residential buildings

**New work:** Ideal for new roofs. The standard kerb is 310mm high with a 90mm base plate.

**For refurbishment and renovation works and for use on an existing kerb:**

- The adapter plate is 170mm high with a foot of 83mm (other sizes are available upon request).

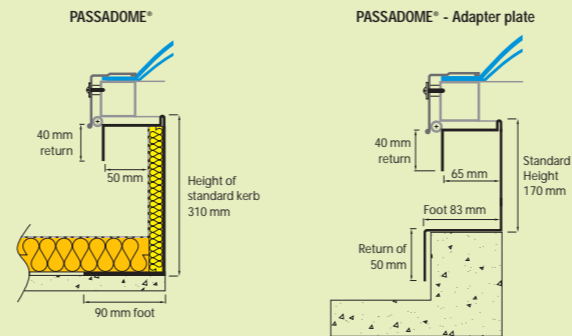

### 3 FUNCTION

The PASSADOME® is opened and closed manually.

An oleopneumatic cylinder helps the unit to open and keeps the opening frame in an open position. The opening of the unit is limited, according to requirements, by a 1m long chain. It is possible to open the unit to 110° without using the chain.

The unit is held in the closed position by a catch which can be locked with a padlock (not supplied).

## ACCESS HATCH/ROOFLIGHT

# PASSADOME®



### 1 ADVANTAGES

PASSADOME® is an opening unit providing roof access and allowing natural daylight into the building. It is opened manually from 0° to 60° simply by adjusting a chain between the opening frame and the kerb (maximum opening is 110° without the use of the chain).

The chain restricts the opening of the access hatch and makes it easier to reach the handle when closing the unit.

**High resistance to corrosion:** the galvanised steel kerb is assembled by crimping.

This assembly technique, used in car manufacturing, avoids the use of welding which then requires subsequent reconditioning to achieve a level of protection equivalent to galvanisation. This means that the PASSADOME® unit has an excellent resistance to weathering and corrosion, even when scratched.

**Colour Finish:** PASSADOME® access hatches are available in galvanised steel or, upon request, in steel and pre-coated in CLASSIC WHITE colour. They can also be painted after manufacture in one of the main RAL colours (thickness of pre-coating: 25µ, thickness of final coating: over 25µ).

PASSADOME® access hatches become an architectural feature of the roof.

### 2 COMPOSITION

PASSADOME® access hatches are made up of the following components:

- **Kerb:** this is the main component of the unit. It supports the opening section or lid as well as the opening mechanism. The standard kerb in galvanised steel is assembled by crimping. It is straight sided and is covered on the outside by bitumen-surfaced thermal insulation designed to accept torch-on waterproofing membranes. In the **Adapter Plate** version an insulated kerb is available upon request. Fire rating: M0. Alternative designs are available for PVC roof membranes.
- **A tubular opening frame in galvanised steel:** the opening frame is equipped with a handle to close the unit and with a PASSADOME® catch locking system.
- **Glazing:** As standard either 10mm reinforced, structured opalescent polycarbonate sheet (PCA) (tested to 1200 joules) or polycarbonate double domes. The following options are also available: 10 and 16mm polycarbonate, triple- or quadruple-walled structured polycarbonate sheet for better thermal resistance, reinforced double domes (tested to 1200 joules) or an aluminium cover. Single dome or pyramid dome available on request. All PCA glazing has anti UV treatment. To choose the type of glazing required, see the table entitled "Glazing - Performance". The positioning of the glazing and the design of our units reduce the build-up of condensation as air circulates between the frame and the kerb.
- **Aluminium beading frame:** fixed by stainless steel screws and nylon washers. This holds the glazing in place and protects edges from lateral impact. It also improves the aesthetic appeal of the PASSADOME®.

### 4 GLAZING - PERFORMANCE

TYPE OF GLAZING	THERMAL TRANSMISSION U (W/m²·°C)	LIGHT TRANSMISSION (%)	FIRE CLASSIFICATION (BUILDING REGULATIONS ENGLAND AND WALES 2002)	ACOUSTIC PERFORMANCE (db (A))
Double polycarbonate domes - opal	3.1	81	Tp(e)	
Double PMMA domes (polymethyl methacrylate)	3.1	76		19
10mm structured polycarbonate - clear	3.1	85	Tp(e)	17
10mm structured polycarbonate - opal	3.1	62	Tp(e)	17
10mm structured polycarbonate - Venetian	3.1	33		17
10mm structured polycarbonate - Comfort	3.1	55		17
10mm structured polycarbonate - 4-walled - opal	2.5	55	Tp(e)	17
16mm structured polycarbonate - clear	2.3	79		21
16mm structured polycarbonate - opal	2.3	57	Tp(e)	21
16mm structured polycarbonate - K clear	2	72		21
16mm structured polycarbonate - K opal	2	57		21
16mm structured polycarbonate - K Comfort	2	50		21
Aluminium cover 10	3.1	0		17
Aluminium cover 20	0.98	0		
Aluminium cover 60	0.6	0		24